

glass.  
by gaviota

Climatika

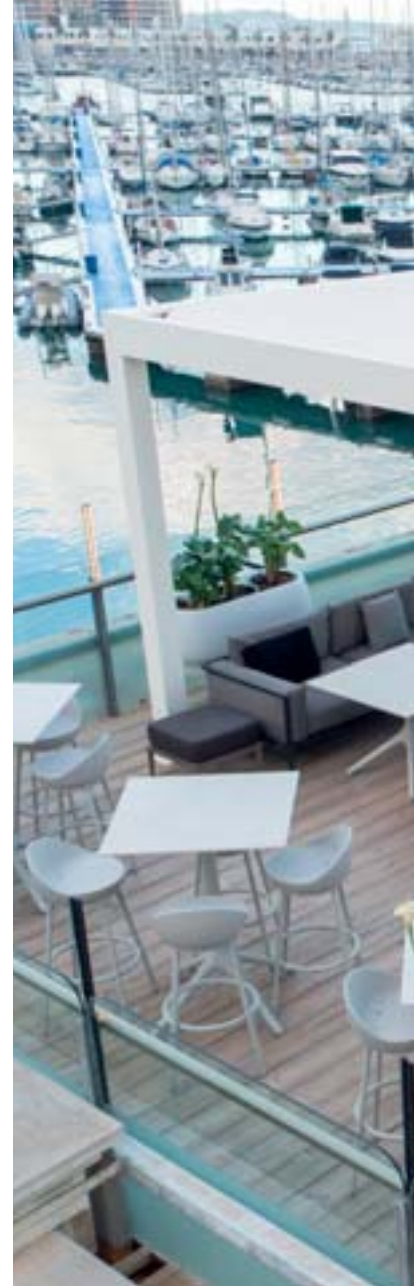



<b>Glass by Gaviota</b> <i>Glass by Gaviota</i>	<b>4</b>
<b>Características</b> <i>Characteristics</i>	<b>6</b>
<b>Desagüe</b> <i>Drainage</i>	<b>8</b>
<b>Lamas</b> <i>Louvers</i>	<b>9</b>
<b>Perfiles y Configuraciones</b> <i>Profiles and Configurations</i>	<b>10</b>
<b>Climatika Plus</b> <i>Climatika Plus</i>	<b>12</b>
<b>Luces Led</b> <i>Led Lights</i>	<b>14</b>
<b>Domótica</b> <i>Domotics</i>	<b>16</b>
<b>Certificación</b> <i>Certification</i>	<b>19</b>
<b>Carta de Colores</b> <i>Colour Chart</i>	<b>22</b>
<b>Sistemas Compatibles</b> <i>Compatible Systems</i>	<b>24</b>
<b>Nuda</b> <i>Nuda</i>	<b>26</b>
<b>Zoe</b> <i>Zoe</i>	<b>28</b>
<b>Nexus</b> <i>Nexus</i>	<b>30</b>

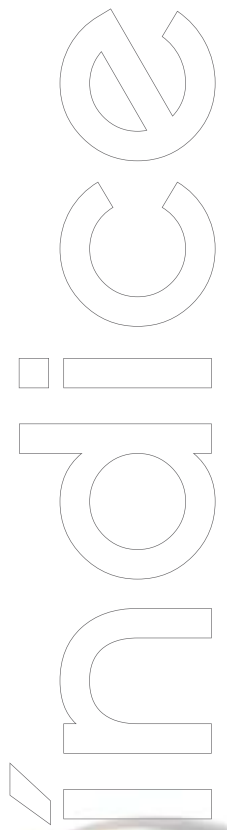







# glass.

by gaviota

Glass by Gaviota es una nueva compañía nacida para acompañar y ayudar a sus clientes a controlar el clima. Con el respaldo del grupo internacional Gaviota, propone maximizar el disfrute y el confort del hogar.

Los sistemas de Glass by Gaviota están diseñados para ahorrar energía, proteger el medio ambiente, reducir la huella de carbono y el impacto del planeta.

Se controla el ciclo productivo, desde el principio hasta tu disfrute, tu satisfacción y todo con la más alta tecnología y los materiales más innovadores.

Desde el año 2021 Glass by Gaviota aúna profesionalidad, transparencia y protección en espacios, exteriores e interiores, a partir de soluciones bioclimáticas que aprovechen al máximo el aporte de luz natural. La firma combina materiales tan adaptables como el vidrio o el aluminio; de entre su extensa y ambiciosa gama de productos, destaca Climatika, líneas rectas y diseño contemporáneo, con muchas opciones de personalización.

*Glass by Gaviota is a new company born to assist and help its customers to control the climate. With the backing of the international group Gaviota, it proposes to maximise the pleasure and comfort of the home.*

*Glass by Gaviota systems are designed to save energy, protect the environment, reduce the carbon footprint and the impact on the planet.*

*The production cycle is controlled, from the beginning to your satisfaction and all this with the highest technology and the most innovative materials*

*Since 2021, Glass by Gaviota has been combining professionalism, transparency and protection in interior and exterior spaces, based on bioclimatic solutions that maximise the most of natural light. The company combines adaptable materials such as glass and aluminium; Among its extensive and ambitious range of products, Climatika stands out, straight lines and contemporary design, with many customisation options.*



## Máxima protección con elegante diseño

Disfrutar del espacio exterior como nunca antes.  
Crear nuevos ambientes y protegerte de cualquier inclemencia del tiempo. Ahora con nuestra pérgola Climatika es posible.  
Ya no importa si hace sol, llueve, hace frío o calor, tú decides tu clima y cómo quieres disfrutarlo.

Además de funcionalidad, comodidad y sostenibilidad, en Glass no hemos dejado atrás el diseño. Por eso con nuestros productos, tu hogar solo puede ganar.

Mecanismos sofisticados, integrados y acordes al diseño. Porque en Glass, cada detalle cuenta.

## Maximum protection with elegant design

Enjoy the outdoors like never before.  
Create new atmospheres and protect yourself from any weather conditions. Now with our Climatika pergola it is possible.  
It doesn't matter if it's sunny, rainy, cold or warm, you decide your climate and how you want to enjoy it.

Besides functionality, comfort and sustainability, in Glass we have not left design aside. That's why with our products, your home can only win.  
Sophisticated, integrated and design-conscious mechanisms. Because at Glass, every detail counts.

 **Conexión Invisible  
y Tornillería oculta**  
Invisible Connection  
and Hidden Screws



**Luces LED**  
LED lights



**Drenaje Agua**  
Water drainage

 **Ángulo**  
Angle



**Motorizado**  
Motorised







**AL** Aluminio  
Aluminium



Auto-Portante  
Self-standing



Posibilidad cierre perimetral  
Perimeter enclosure option



Posibilidad Bicolor  
Two-colour Option



Plana  
Flat



Marca CE  
CE Marking



Resistencia a los fenómenos  
atmosfericos  
Weather Resistance



Integración con otros  
Sistemas de Gaviota  
Integration with other  
Gaviota Systems



## Desagüe— Drainage

Disfruta de la lluvia sin mojarte.  
Toda el agua se recoge en los canalones  
especialmente diseñados y se redirige a los  
desagües.

*Enjoy the rain without getting wet.  
All the water is collected in the specially designed  
gutters and is redirected to the drains.*





Elección de la dirección de apertura



Opening direction option

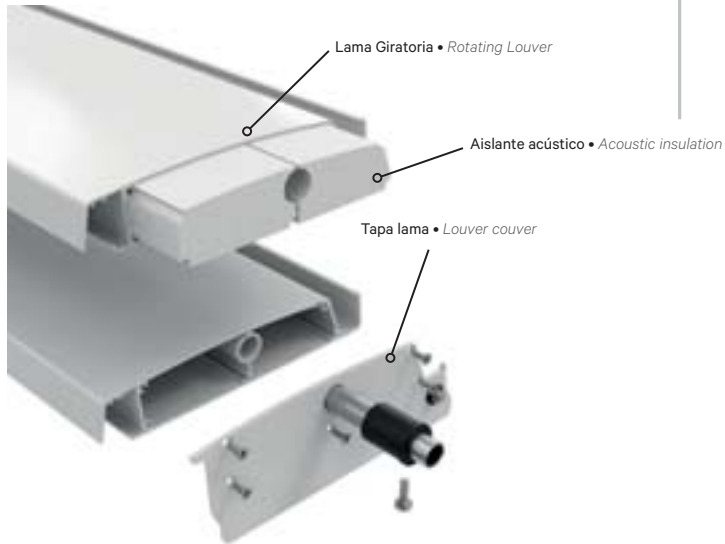
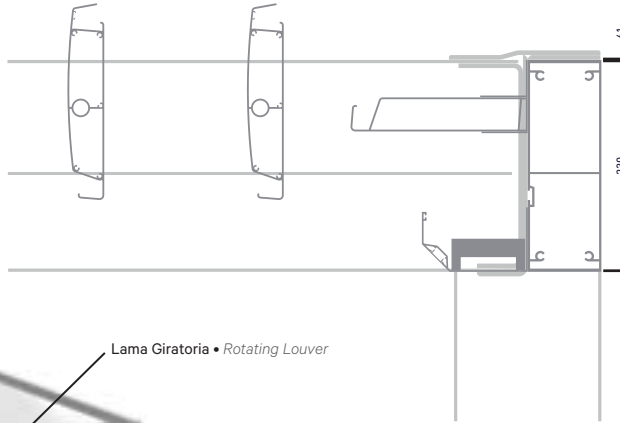

## Lamas giratorias

Climatika permite controlar tu clima, ya que las lamas giratorias del techo protegen de lluvia o nieve en los meses más fríos, y suponen una total protección de los rayos del sol durante el verano, y en diferentes posiciones abiertas permiten la ventilación y circulación del aire además del control de la luz solar.

### Rotating Louver

Climatika allows you to control your climate, as the rotating louvers on the roof protect you from rain or snow in the coldest months, and provide full protection from the sun's rays in the summer, and in different open positions they allow ventilation and air circulation as well as sunlight control.

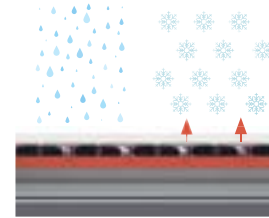
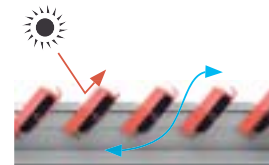
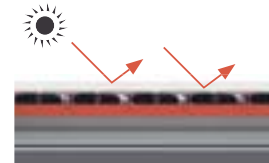
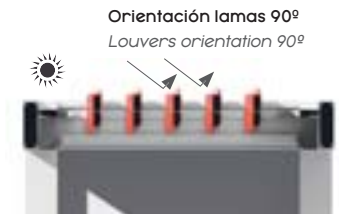



## Perfiles — Profiles

Soporte Lama • Louver support Perfil Canalón LED • Profile Gutter LED

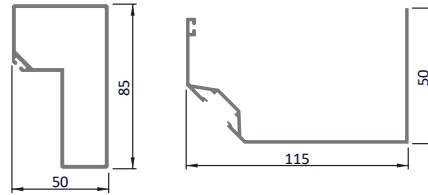

Soporte Lama Fija • Fixed Louver Support



Lama Fija • Fixed Louver

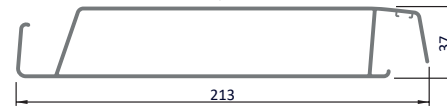

Lama Giratoria LED • Rotating Louver LED

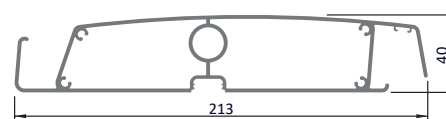

Lama Giratoria • Rotating Louver

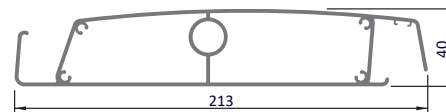

Perfil Poste • Column Profile

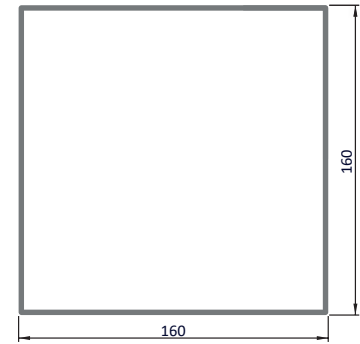

Perfil Refuerzo Viga  
Reinforcement Beam Profile

Perfil Viga • Beam Profile

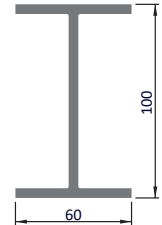
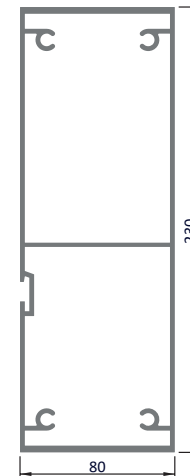

Medidas en mm • Measure in mm

## Configuraciones — Configurations

### Módulos simples • Simple modules



Autoportante  
Self-standing



Pared Portería lama paralela a pared  
On facade Louvers parallel to the wall

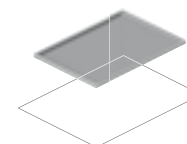

Entreparedes  
Between walls



Pared Portería lama perpendicular a pared  
On facade Louvers perpendicular to the wall

### Módulos múltiples • Multiple modules

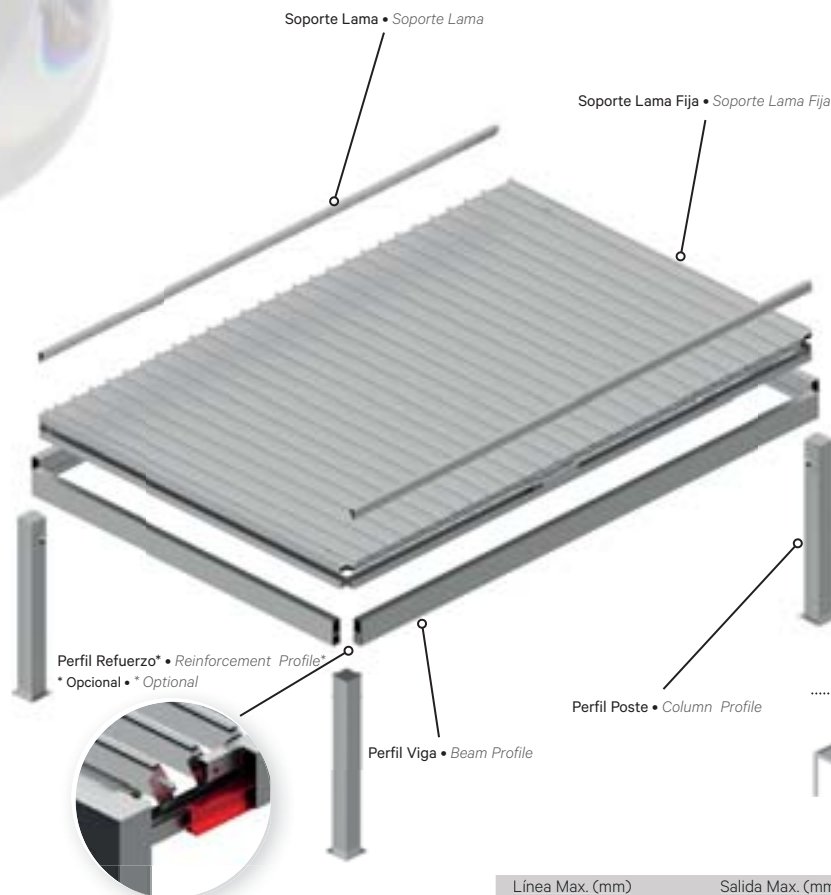
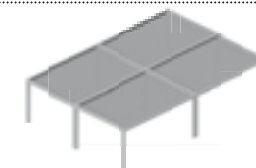

Soporte Lama • Soporte Lama

Soporte Lama Fija • Soporte Lama Fija

Perfil Refuerzo\* • Reinforcement Profile\*  
\* Opcional • \* Optional

Perfil Poste • Column Profile

Perfil Viga • Beam Profile



Línea Max. (mm) Max. Width (mm)	Salida Max. (mm) Max. Projection (mm)	Ancho Columnas (mm) Column size (mm)	Accionamiento Operation	Clase viento UNE-EN 13561 Wind class UNE-EN 13561
------------------------------------	--	---	----------------------------	--

Autoportante  
Self-standing  
Pared Portería Lama paralela a pared  
On facade Louvers parallel to the wall  
Pared Portería Lama perpendicular a pared  
On facade Louvers perpendicular to the wall  
Entreparedes  
Between walls

4200	6000	160x160	Motor	6
4200	6000	160x160	Motor	6
6000	4200	160x160	Motor	6
4200	6000	NO	Motor	6



¡Inovación!  
¡New!

# Climatika Plus



Sección Vigas Centrales  
Central Beams Section



Detalle unión Vigas Centrales con Viga Plus  
Detail of connection between Central Beams and Plus Beam

Medidas máximas Maximum dimensions	Línea L (mm) Width L (mm)	Salida. S (mm) Projection S (mm)
	7000	6000

Sección —  
Section

Perfil Viga Plus • Beam Plus profile

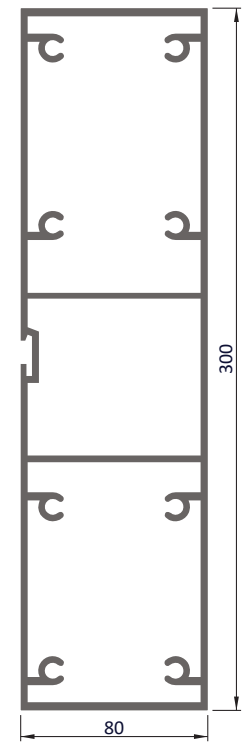

## Luces LED —

¡Crea tu propio ambiente, sea de día o de noche!

¡Tú eliges cómo con un sinfín de posibilidades de personalización!

- Tiras LED integradas en el perímetro de la estructura: puedes elegir entre luz blanca o RGB de colores programable.
- Tiras LED integradas en lama: puedes elegir entre luz blanca o RGB de colores.
- Spot LED integrados en lama: puedes elegir entre 4 o 8 spots.

## LED lights

*Create your own ambience, day or night!*

*You choose how with endless personalisation possibilities!*

- *LED strips integrated in the perimeter of the structure: you can choose between white light or programmable coloured RGB.*
- *LED strips integrated in the slat: you can choose between white or coloured RGB light.*
- *LED spots integrated in the slat: you can choose between 4 or 8 spots.*









## Domótica —

¿Quieres sol y brisa o protección total?

Abre y cierra las lamas con un solo click en segundos, gracias al nuevo motor mas rápido y silencioso del mercado. Además puedes hacerlo tanto con el mando como con tu móvil.

### Home automation

*Do you want sun and breeze or full protection?*

*Opens and closes the louvers with a single click in seconds, thanks to the fastest and quietest new motor on the market.*

*And you can do it both with the remote control and with your mobile phone.*

## Motor mando y receptor —

Remote control and receiver



Motor hidráulico de brazo  
Hydraulic arm motor



Central receptora  
Central receiver



Mando 6 canales  
Remote control 6 channels

### Todo en 1 desde el mismo mando:

- Controlar la apertura y cierre de las lamas.
- Controlar la iluminación perimetral y en las lamas.
- Controlar los sistemas verticales gracias a la centralita especial.

### All in 1 from the same remote control:

- Control the louvers opening and closing.
- Control perimeter and louvers lighting.
- Control vertical systems thanks to the special control unit

## Sensores —

No tienes que preocuparte por nada con los sistemas de domotica y los sensores de última generación que en todo momento y te ayudan a crear un clima perfecto y proteger tu pérgola.

### Sensors

*You don't have to worry about anything with home automation systems and high-tech sensors that help you create the perfect climate and protect your pergola at any moment*



## Accesorios y conectividad

### Accessories and connectivity



Sensor de Lluvia  
The rain sensor

El sensor de lluvia te ofrece de la seguridad de que ni una gota de agua pueda impedirte disfrutar de tu pérgola. Disfruta de la lluvia como nunca has podido.

*The rain sensor gives you the security that not even a drop of water can stop you from enjoying your pergola. Enjoy the rain like never before.*



Sensor de Viento  
The wind sensor

El sensor de viento actúa en caso de viento fuerte y abre las lamas para que la estructura no sufra ningún daño. El sensor de viento prevalece sobre el de lluvia.

*The wind sensor acts in the case of a strong wind and opens the louvers so that the structure does not suffer any damage. The wind sensor takes over the rain sensor.*



Sistema de sonido  
bluetooth  
Bluetooth sound  
system.

¿Te gusta la música y no te imaginas tu vida sin ella? No te preocupes, ahora puedes disfrutar de ella incluso en exteriores con nuestro sistema de sonido por bluetooth.

*Do you love music and can't imagine your life without it? Don't worry, now you can enjoy it even outdoors with our bluetooth sound system.*



APP Apple y Android  
APP Apple and Android

¿Te imaginas con solo tu móvil poder abrir y cerrar las lamas, apagar o encender las luces e incluso cambiar el color de iluminación RGB? Todo es posible con la APP.

*Can you imagine being able to open and close the louvers, turn the lights on or off and even change the colour of the RGB lighting with just your mobile phone? It's all possible with the APP.*







## Certificación

Climatika cumple con los máximos estándares de seguridad y está homologada en Clase 6 de Resistencia al viento en sus medidas máximas de un módulo de 4.2 x 6 x 3m según norma europea UNE-EN 1932:2014 Toldos y Persianas.

Cuenta con el cálculo estructural según normas UNE EN 13561, UNE EN 1993-1-8, UNE ENV 1991-2-4 y el Código Técnico obteniéndose los siguientes resultados:

### Certification

*Climatika complies with the highest safety standards and is approved in Class 6 of wind resistance in its maximum measures of a module of 4.2 x 6 x 3m according to European standard UNE-EN 1932:2014. Awnings and blinds.*

*It has the structural calculation according to the UNE EN 13561, UNE EN 1993-1-8, UNE ENV 1991-2-4 and the Technical Code, obtaining the following results:*

Estructura • <i>Structura</i>			
Configuración <i>Configuration</i>	Velocidad viento <i>Wind speed</i>	Presión estática equivalente <i>Equivalent static pressure</i>	Carga de nieve <i>Snow loading</i>
Cubierta cerrada <i>Closed deck</i>	47,8 km/h	110Pa	65kg/m2
Cubierta abierta <i>Open deck</i>	128,8 km/h	800Pa	

NOTA: Los resultados de los ensayos de resistencia al viento han sido obtenidos con los productos fabricados por Gaviota Simbac que se detallan en los correspondientes informes de ensayo.

*NOTE: The results of the wind resistance tests have been obtained with the products manufactured by Gaviota Simbac which are specified in the corresponding test reports.*



glass.  
by gaviota







**Carta de Colores —**  
*Colour Chart*



**Blanco Gaviota**  
*Gaviota White*



**Bronce Texturado**  
*Textured Bronze*



**Gris 7016 Texturado**  
*Textured Grey 7016*



**Blanco Texturado**  
*Textured White*



**Negro Texturado**  
*Textured Black*



**Plata Texturado**  
*Textured Silver*



**Marrón 8014**  
*Brown 8014*



**Beige 1013**  
*Beige 1013*



**Ral Especial**  
*Special Ral*

Personaliza tu Climatika y elige color de la estructura y de la lama.

Hasta puedes combinar 2 colores si quieres. Y si prefieres otro color, consulta nuestra Carta RAL.

*Personalise your Climatika and choose the colour of the structure and the louver.*

*You can even combine 2 colours if you want. And if you prefer another colour, consult our RAL chart.*

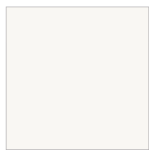

40100407

Ultra Mate Bianco TG

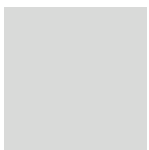

40100411

Ultra Mate Silver Anodizado



40100414

Ultra Mate Griggio Classico



40100409

Ultra Mate Marino



40100410

Ultra Mate Gold



40100412

Ultra Mate Terra



40100408

Ultra Mate Vino



40100415

Ultra Mate Marrone



40100413

Ultra Mate Nero Anodizado







cortinas  
de cristal  
screens

glass curtain

Sistemas Compatibles *Compatible Systems*

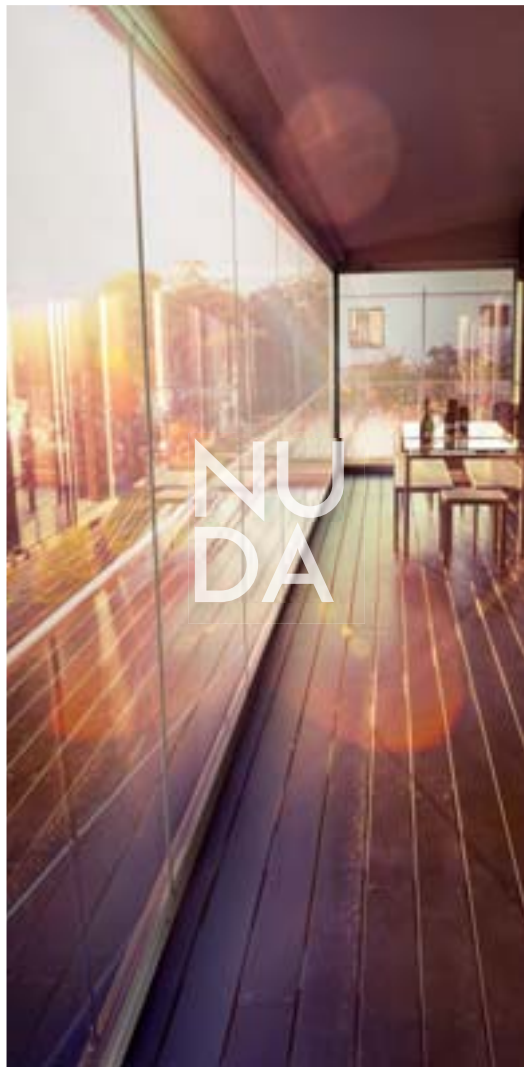

**Cortina Cristal Abatible**  
*Folding Glass Curtain*



**Cortina Cristal Corredera**  
*Sliding Glass Curtain*



**Screen**  
*Screen*

## NUDA

Abatible • Folding

Sistema de cerramiento acristalado deslizante y giratorio sin perfiles verticales que proporciona un excelente aislamiento térmico y acústico.

*Sliding and retractable glass closure system without vertical profiles. NUDA provides an excellent thermal and acoustic insulation.*







Fijación Bisagra Inferior  
Lower Hinge Fixing



Soporte Inox Superior  
Upper Stainless Steel Support

Apertura + Tapa  
Opening + Cover



Soporte Fijación y pestillo  
Fixing bracket and lock



Tapas herméticas  
Hermetic caps



## Se distingue por

- Sistema de rodamientos en guía superior mediante un mecanismo de desplazamiento horizontal, con doble rodamiento de fácil deslizamiento.
- Guía inferior de dos tipos: sobrepuesta y embutida.
- Sistema de agrupación de paneles mediante clipaje de las hojas.
- Sistema de apertura intermedia que permite una ventilación controlada.
- Perfil de hoja único tanto para vidrio de 8 mm como para vidrio de 10 mm
- Reduce los gastos en climatización.
- Posibilidades geométricas sobre cualquier ángulo entre 90° y 180°.

## Se distingue por

- Bearing system in top guide through a mechanism of horizontal scrolling, with easy sliding double bearing.
- Lower guide of two types: overlapped and embedded.
- Panel grouping system by clipping the panels.
- Intermediately open system which allows controlled ventilation.
- Single panel profile for both 8 mm and 10 mm glass.
- It helps to reduce costs and expensis for heating and air conditioning
- Different geometric possibilities with angles from 90° and 180°.

Recomendado hasta • Recommended For up to

Vidrio 8 (mm) • Glass 8 (mm)		Vidrio 10 (mm) • Glass 10 (mm)	
<b>Hojas • Panels</b> 0,80 línea x 2,00 altura (m) 0,80 width x 2,00 height (m)	<b>Sistema (m) • System (m)</b> Peso máximo línea hojas: 425 Kg x 2,20 altura Maximum weight panel width: 425 Kg x 2,20 height	<b>Hojas • Panels</b> 0,70 línea x 2,50 altura (m) 0,70 width x 2,50 height (m)	<b>Sistema (m) • System (m)</b> Peso máximo línea hojas: 425 Kg x 2,70 altura Maximum weight panel width: 425 Kg x 2,70 height

## ZOE

Cortina de cristal deslizante de diseño sencillo sin marcos laterales del vidrio, que cuenta con un apoyo inferior para facilitar el desplazamiento del cristal.

*Sliding glass curtain with a simple design without glass side frame, resting on the bottom part that makes glass panels running very smooth.*





**Carro doble regulable**  
*Adjustable double cart*



**Tapa Guía Superior**  
*Upper guide cover*

**Perfil Hueco Guía Superior**  
*Upper guide rail profile*

**Tapa Guía Inferior**  
*Bottom guide cover*

**Tapa Hoja**  
*Panel cover*



**Se distingue por**

- Guías de 3, 4, 5 y 6 carriles.
- Sistema de condensación mediante una cámara interior inclinada en la guía inferior para la recogida de agua por condensación.
- NUEVA GUÍA INFERIOR de dos tipos de instalación: sobrepuesta y embutida.
- Nuevos carros regulables hasta 5mm con rodamientos dobles.
- Tapas metálicas lacadas de guías superior e inferior.
- Cerrojillo inferior que permite el bloqueo manual del primer panel en la parte inferior del cerramiento.

**Distinguished by**

- Guides of 3, 4, 5 and 6 rail.
- Condensing system through an inclined internal channel located at the bottom guide to gather the condensed water.
- NEW BOTTOM GUIDE with two types of installation: overlapped and embedded.
- New carts adjustable up to 5mm with double wheels.
- Painted metallic caps for bottom and upper guides.
- Lower locking mechanism that allows a manual blocking of the first panel at the bottom of the enclosure.

Recomendado hasta • *Recommended For up to*

Vidrio 10 (mm) • Glass 10 (mm)			
Medida máxima Hoja <i>Panel maximum sizes</i>	Medida mínima Hoja <i>Panel minimum sizes</i>	Apertura Simple <i>Simple opening</i>	Apertura Doble <i>Double opening</i>
1,00 línea x 3,00 altura (m) <i>1,00 width x 3,00 height (m)</i>	0,27 línea x 0,30 altura (m) <i>0,27 width x 0,30 height (m)</i>	5,91 línea x 3,10 altura (m) <i>5,91 width x 3,10 height (m)</i>	11,53 línea x 3,10 altura (m) <i>11,53 width x 3,10 height (m)</i>



## NEXUS

Este minucioso sistema contiene un cierre lateral de lona mediante cremallera, lo que permite una gran y destacada resistencia al viento en este tipo de Screen.

*This detailed system has a side zip fabric closure, which allows a great wind resistance in this Screen type.*





## 2 Formas de Cajón

- Cuadrado
- Curvo

## 2 Forms of box

- Square
- Curved



Elegante sistema diseñado especialmente para que el tejido no se salga de las guías, gracias a las cremalleras Zip.

*Elegant system specially designed so that the fabric does not come out of the guides thanks to the Zip.*

Recomendado hasta • *Recommended For up to*

Cajón <i>Box</i>	Línea x Altura <i>Width x Height</i>
100	4000 x 3500
100	4000 x 3500

Cajón <i>Box</i>	Línea x Altura <i>Width x Height</i>
130	5000 x 5000
	6000 x 3500
130	6000 x 3500

## 2 Tipos Guías Zip

- Guía estrecha 33 x 48 mm
- Guía ancha 49 x 48 mm

## 2 Types of Zip Guides

- Wide guide 33x48 mm
- Narrow guide 49x48 mm



## Se distingue por

- Accionamiento motorizado.
- Gran resistencia al viento.
- Cierre lateral de la lona mediante cremallera.

## *Distinguished by*

- *Motorised operation.*
- *High wind resistance.*
- *Side closing of the fabric by zip*

glass.

by gaviota



















**glass.**  
by gaviota

Calle de la Térmica, 4  
03638 Salinas (Alicante) - España / Spain  
[hola@glassbygaviota.com](mailto:hola@glassbygaviota.com)  
[www.glassbygaviota.com](http://www.glassbygaviota.com)